

AQUAFIX

MILIEU®

Aquafix Milieu presents SUMPS & BUFFER TANKS

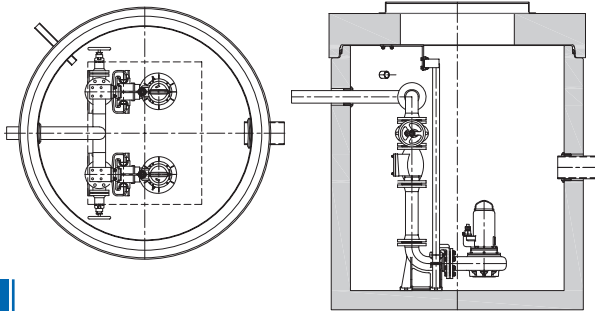
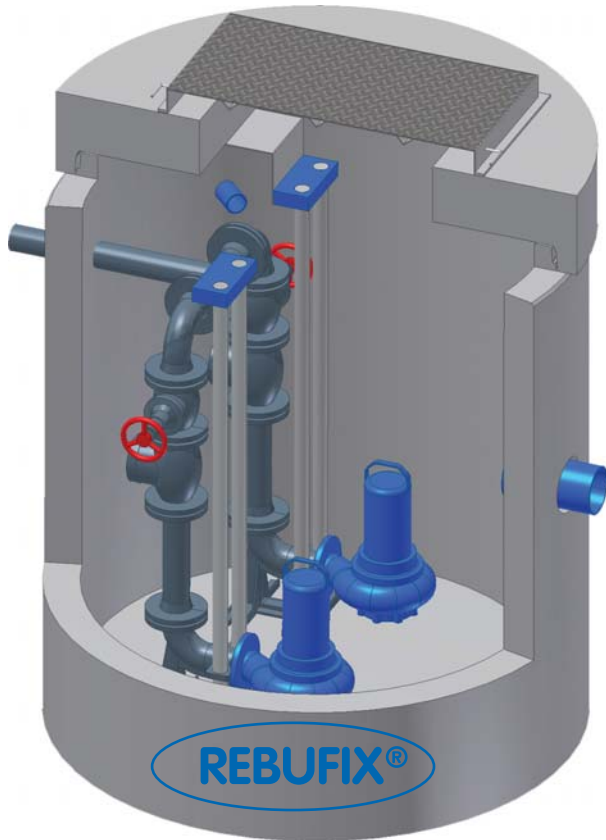

REBUFIX®

TANKS

We proudly present our new range of sumps and buffer tanks to complement our existing ranges of grease traps, and oil/fuel and parallel plate separators. We manufacture these products at our factory in either circular or rectangular-shaped prefabricated reinforced concrete. These sumps are also available in HDPE and AISI 304/316 stainless steel (suitable for high water temperature applications).

HDPE and stainless steel sumps can be manufactured according to your own particular specifications to help solve all your wastewater management problems. Rectangular concrete sumps are available in the following sizes: 600 x 600 mm, 800 x 800 mm, 1000 x 1000 mm, 1100 x 1100 mm, 1250 x 1250 mm, 2250 x 1250 mm and 4000 x 1500 mm. Using our own assembly jig, we can manufacture any sump size required up to a maximum capacity of 60,000 L. You can determine the height of any of our models.

Circular concrete sumps are available with the following internal diameters: 800 mm, 1000 mm, 1200 mm, 1500 mm, 2000 mm, 2500 mm and 3000 mm. These sumps are also available in virtually any height to match your requirements and help solve your wastewater management problems.

At our modern manufacturing facility in Mijdrecht (NL), we can even install the pump of your choice. Main brands include Homa, Grundfos, ABS, ITT Flygt, KSB, Wilo and Tsurumi pumps, but also countless other brands. We can also fit auto-couplings, guide rails, ball check valves, cut-off valves, lifting chains, and even switchboxes and pressure transducers. Our office and field sales staff can advise you about the right pump to use. We will even provide a pipe calculation and quotation – without charge or obligation – to help you solve your wastewater management problem quickly and simply, and within budget.

We can fit all sumps and buffer tanks with your own choice of connections such as inlets, cable feeds, bleeds and outlets. We have facilities at our factory to drill cores in concrete sumps up to 630 mm in diameter. Using special rubber tubing, we can create watertight seals around these connections at any position or height specified, quickly and simply.



REBUFIX®



BENEFITS:

- Wide range of capacities from 200 to 60,000 L
- Virtually all dimensions and installation depths available
- Also suitable for chemical/corrosive wastewater (stainless steel/HDPE T-Grip models)
- Various models available with projecting reinforcements
- Connection diameters from 32 to 630 mm (rectangular openings also possible)
- Extensive range of pump brands available
- Complete system construction and assembly. Systems delivered ready-to-connect
- Customized solutions available, if required, within 24 hours, and subject to inventory levels

OPTIONS:

- Heavy-duty traffic covers
- Attachments (for increased installation depths)
- Switchboxes and alarms
- Maintenance and repair contract
- Manufactured to specification

CERTIFICATION:

- CE approval mark
- Concrete is KIWA certified in compliance with BRL 5070

APPLICATIONS:

All situations in which the sewer is lower than the discharge point and where height differences need to be accommodated, such as:

- Separator outlets
- Loading docks
- Site drainage
- Hospitality industry
- Toilet facilities
- Army bases
- Airfields
- Camping sites
- Homes/businesses
- Industry

The Netherlands' largest
separator manufacturer

We are currently looking for dealers/resellers. Our sales manager speaks English and German.

P.O.Box 288, 3640 AG MIJDRECHT THE NETHERLANDS T: 0031-297-262929 F: 0031-297-261272 www.aquafix.eu